

1542-KERB LIFTER

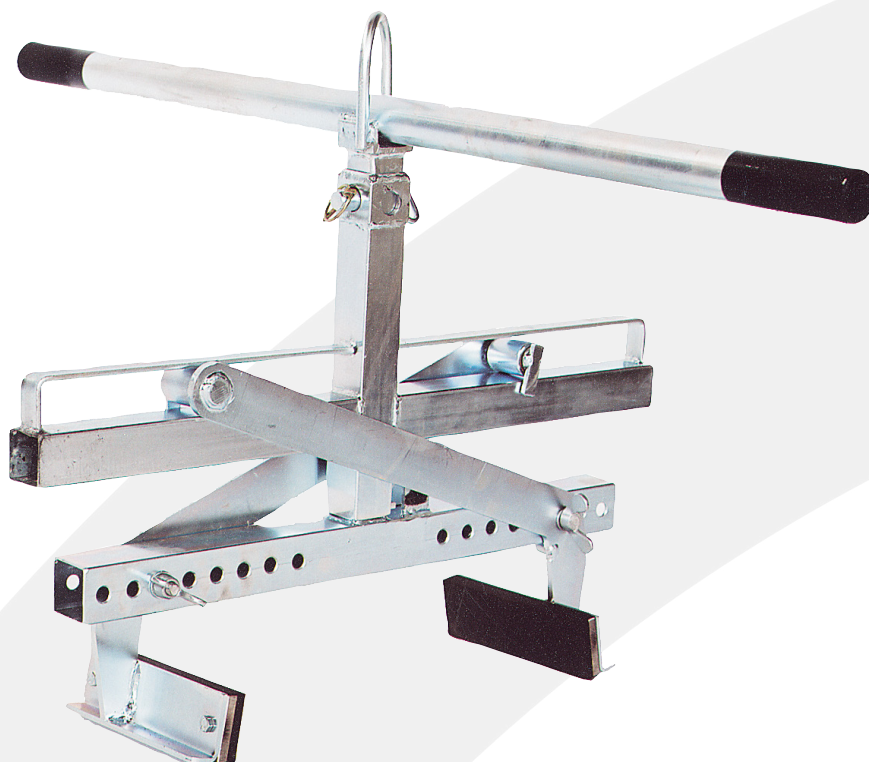

For the safe transportation and placement of kerbs, steps, edging angles and similar. Designed for universal use, with a wide, adjustable opening range, and suspension lug for crane hooks or handle for carrying by hand. Replaceable rubber-lined jaws.

Item Code	SWL (Kg)	Grab Range (mm)	Internal Depth (mm)	Weight (kg)
1542.1	250	50-540	130	18

Eichinger Equipment Ltd
69-73 James Road, Frimley, Camberley, GU15 2RH
T: 01276 605 970 F: 01276 682 913 E: sales@eichinger.co.uk

The following instructions must be read and understood by each intended user of this equipment; if there is anything you do not understand contact Eichinger Equipment Ltd.

Ensure the equipment is adequate for the job you need to carry out.

You must not operate this equipment if you are under the influence of alcohol, drugs or if you are feeling unwell.

A risk assessment should be carried out prior to moving or using this equipment.

The following PPE (Personal protective equipment) should be worn when using this equipment:

Gloves / Goggles / Hard Hat / Steel Toecap boots / Hi-Vis Vest

We also suggest suitable clothing should be worn.

Familiarise yourself with the equipment, its use and how it works!

As this equipment is used at multi-level, ensure the intended area for use is clear of overhead cables and power lines or similar hazards which may affect its safe use. This equipment must always be used in conjunction with your site safety policies.

The work area must be clear of obstructions with adequate space for the operative to work safely around the equipment.

Check and ensure the equipment is inspected and in a safe condition prior to its use. Also ensure that its load is stable and secure.

SETUP

The kerb lifter is equipped with a lift ring. The ring, in conjunction with other equipment such as chains and hooks, enables the operator to hang the kerb lifter to almost any hoist.

Adjustment of the clamping range.

The kerb lifter can lift loads of different sizes if it is adjusted before each use.

To adjust the clamp range, loosen the wing nuts and pull them out.

Adjust the telescopic jaws to reach the desired clamping range. Make sure the jaws are placed symmetrically and are no more than 20 mm away from the load.

Insert the wing nuts in the appropriate holes and tighten.

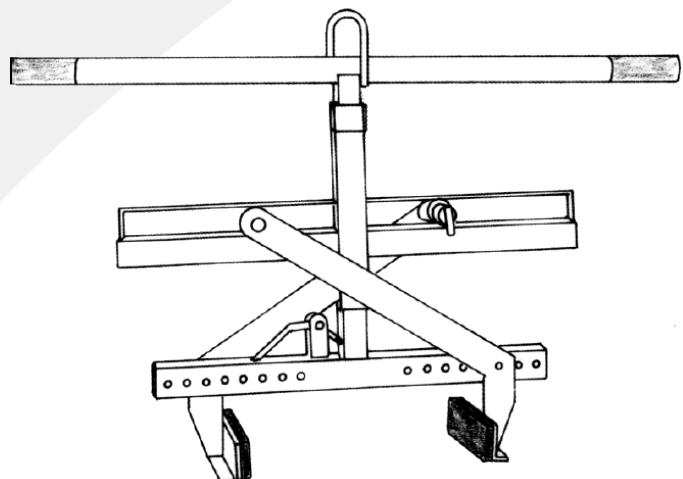

WARNING!

Do not use this equipment for dragging loads; it should be used for lifting loads clear of the ground only. Always ensure that the forks are set to the correct width for each load lifted.

REMEMBER:

To avoid the risk of injury keep hands and feet clear of the unit at all times during use. Only use safety handles to manoeuvre the unit during use and only when it is safe to do so. At no time should anyone either trained personnel or otherwise be allowed under the raised load or near enough to be at risk in the event that the load moves.



USING THE EQUIPMENT

Attach the kerb lifter to the hoist or have two persons use the handles for manual operation.

Adjust the clamping range.

Position the kerb lifter across the center of the load and lift the unlocking lever until the jaws are touching the load.

The kerb lifter may now be lifted with the load.

When the load is set down, the kerb lifter opens automatically and then locks again, allowing the kerb lifter to be lifted clear of the load.

If there is too little room to work, turn the kerb lifter's handles 90°.

Take out the cotter pins' hinged locking pins and then remove the cotter pins.

Pull the handle out of the rectangular tube and turn 90°.

Put the cotter pins back in place and secure with the hinged locking pins.

